



Planetary Mixers Planetary Mixer for Bakery, 40 lt. - Electronic + hub

ITEM # _____

MODEL # _____

NAME # _____

SIS # _____

AIA # _____



600172 (DMBE40AB)

40 lt planetary mixer, bowl detection device and SOLID BPA free safety screen, with 3 fixed speeds and variable speed. Equipped with spiral hook, paddle, whisk and attachment hub type H. Suitable for bakery preparations

Short Form Specification

Item No. _____

Suitable for bakery and pastry making, for kneading, blending and whipping operations. Reinforced body for heavy duty use with 18/8 (AISI 302) 40 litre capacity stainless steel bowl. Reinforced transmission and powerful asynchronous motor (2200W) with 3 fixed speeds (40,80,160 rpm) and electronic variable speed (from 30 to 175 rpm). Water proof (IP55) and flat touch button control panel with a timer from 0-59 min. Removable/transparent solid safety screen - made of a bisphenol-A free (BPA) copolyester. Removable and dismantled solid safety screen and stainless steel wire structure. Kneading: speed 1 or 2 with hook; Blending: speed 2 with paddle; Whipping: speed 3 with whisk. Bowl detection device allows the mixer to switch on only when the bowl and the safety screen are properly installed and positioned together. Equipped with accessory drive hub type H (accessories are not included). Supplied with 3 tools: spiral hook, paddle and reinforced whisk.

APPROVAL: _____

Main Features

- Delivered with:CHAR(10)- Spiral Hook, Paddle, Wire Whisk and Mixing Bowl for 40lt.CHAR(10)- Accessory drive hub (accessories are not included).
- Emulsifying speed: "3" with whisk.
- Raising and lowering of the bowl controlled by lever with an automatic locking of the bowl when in the raised position.
- Kneading speed: "1" with hook.
- Mixing speed: "2" with paddle.
- Waterproof touch button control panel with timer, speed setting and display.
- Professional beater mixer designed to withstand the strong demands of bakery and pastry making.
- Maximum capacity (flour, with 60% of hydration) 10 kg.
- Solid BPA-free safety screen, covering the stainless steel wire one, limits the flour and unsafe dust particles when used in bakery and pastry preparation.
- Removable chute to add ingredients while working included as standard.
- Bowl detection device allows the mixer to switch on only when the bowl and the solid safety screen are properly installed and positioned together.

Construction

- 3 fixed speeds: 40, 80 and 160 rpm.
- 302 AISI Stainless steel bowl - 40 lt. capacity.
- Water protected planetary system (IP55 electrical controls, IP23 overall machine).
- Electronic speed variator (10 speeds available from 30 to 175 rpm)
- Reinforced body, feet and transmission for heavy duty operations.
- Power: 2200 watts.
- Aluminium accessory hub positioned on the left side of the head of the planetary mixer.
- The solid safety screen and the stainless steel wire structure are both removable and dismantled for cleaning and are dishwasher safe.
- Adjustable feet for perfect stability.

Included Accessories

- 1 of BOWL FOR 40LT MIXER PNC 650128
- 1 of DOUGH HOOK FOR 40LT MIXER PNC 653092
- 1 of PADDLE FOR 40LT MIXER PNC 653093
- 1 of REINFORCED WHISK FOR MB/MBE40 MIXERS PNC 653127

Optional Accessories

- 20L BOWL,HOOK,PADDLE, WHISK FOR 40L MIXER PNC 650126
- BOWL FOR 40LT MIXER PNC 650128

Planetary Mixer for Bakery, 40lt. - Electronic + hub



Planetary Mixers Planetary Mixer for Bakery, 40 lt. - Electronic + hub

- Bowl scraper 40 lt PNC 650186
- DOUGH HOOK FOR 40LT MIXER PNC 653092
- PADDLE FOR 40LT MIXER PNC 653093
- FINE WHISK(EMULSIONS)FOR MB/MBE40 MIXERS PNC 653094
- REINFORCED WHISK FOR MB/ MBE40 MIXERS PNC 653127
- PUREE STRAINER FOR H HUB WITH 3 GRIDS PNC 653187
- VEGETAB.CUTTER H HUB+ EJECTOR-DISCONNECT. PNC 653225
- BOWL TROLLEY-40/60/80LT PLANETARY MIXERS PNC 653585
- EXT.SUPPORT(ALUM)-MEAT MINCER 70MM-H HUB PNC 653720
- ALUM.MEATMINCER KIT 70MM-H HUB-ENTERPRIS PNC 653721
- S/S MEATMINCER KIT 70MM-H HUB-ENTERPRISE PNC 653722
- S/S MEATMINCER KIT 70MM-H HUB-½ UNGER PNC 653723
- EXT.SUPPORT(ALUM)-MEAT MINCER 82MM-H HUB PNC 653724
- S/S MEATMINCER KIT 82MM-H HUB-ENTERPRISE PNC 653725
- ALUM.MEATMINCER KIT 82MM-H HUB-ENTERPRIS PNC 653726
- S/S MEATMINCER KIT 82MM-H HUB-½ UNGER PNC 653727



Front

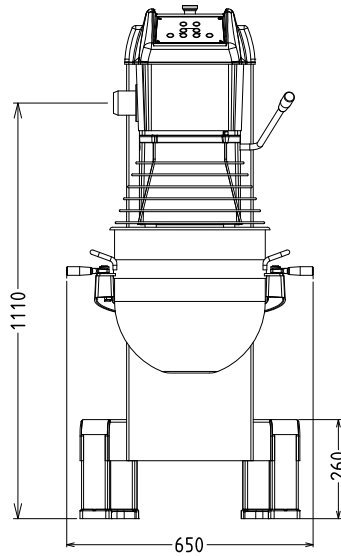

Electric

Supply voltage: 200-240 V/1N ph/50/60 Hz
Electrical power max.: 2.2 kW
Total Watts: 2.2 kW

Capacity:

Performance (up to): 10 kg/Cycle
Capacity: 40 litres

Key Information:

External dimensions, Width: 655 mm
External dimensions, Depth: 850 mm
External dimensions, Height: 1370 mm
Cold water paste: 10 kg with Spiral hook
Egg whites: 70 with Whisk

Side

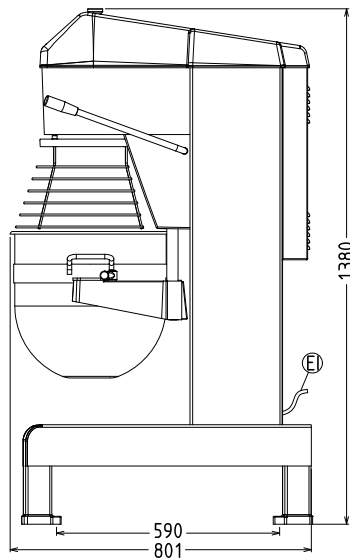

EI = Electrical inlet (power)

Top

